

Product information presented here reflects conditions at time of publication. Consult factory regarding discrepancies or inconsistencies.

MAIL TO: P.O. BOX 16347 • Louisville, KY 40256-0347
SHIP TO: 3649 Cane Run Road • Louisville, KY 40211-1961
(502) 778-2731 • 1 (800) 928-PUMP • FAX (502) 774-3624

visit our web site:
www.zoeller.com

COMPARE THESE FEATURES

- Non-clogging vortex impeller.
- Durable cast construction. Cast iron switch case, motor and pump housing, base and impeller. No sheet metal parts to rust or corrode. All cast iron class 25-30 25000# tensile strength.
- Stainless steel screws, bolts, float rod, handle, guard and arm and seal assembly.
- Shaft Seal - Carbon & ceramic rotary face seal, with stainless steel wetted parts.
- UL Listed 3-wire neoprene cord and plug. 10 ft. standard for automatic. 15 ft. standard for nonautomatic.
- Upper sleeve bearing and lower ball bearing running in a bath of oil.
- Maximum temperature for sewage or dewatering 130°F (54°C).
- Motor - 60 Hz, 1750 RPM, oil-filled, hermetically sealed, automatic reset thermal overload protected (1 Ph and Auto 3 Ph).
- All models are available in 2" or 3" discharge.
- All models pass 2 inch spherical solids.
- Automatic units available with float operated, submersible (NEMA 6) mechanical switch. Available in both 1 and 3 Phase Units.**
- Corrosion resistant powder coated epoxy finish.
- On point 15¼", Off point 5¼".
- Major width 13 9/16". Major height 18 13/16". (Single seal pumps)

**MODELS 4282-4284
DOUBLE SEAL PUMPS (nonauto only)**

- Protects motor from seal leaks.
- Improved bearing lubrication.
- Helps eliminate seal and bearing damage from dry runs.
- Major width 13 9/16". Height 20 11/16".

NOTE: The sizing of effluent systems normally requires variable level float(s) controls and properly sized basins to achieve required pumping cycles or dosing timers with nonautomatic pumps.

*
Tested to UL Standard UL778

282 - 284 Single Seal Series
4282 - 4284 Double Seal Series

(For Pump Prefix Identification see News & Views 0052)



"WASTE-MATE"
SUBMERSIBLE
SEWAGE
OR DEWATERING PUMP
2" OR 3" FLANGED DISCHARGE • PASSES 2" SOLIDS

*
Certified to CSA Standard C22.2 No. 108



**AUTOMATIC THREE
PHASE
PUMP****



NEW!

**SINGLE
SEAL
PUMP**



**DOUBLE
SEAL
PUMP**





**POWDER
COATED
TOUGH™**

MODELS AVAILABLE

• Automatic or Nonautomatic with single seal	• Single phase or three phase motors available.
• Nonautomatic with double seals	• See selection chart for specifications or specific models.
• 2" or 3" discharge.	

*NOTE: No UL Listing or CSA Certification for 200V 1Ph or Extra Duty (ED) pumps. See back page for UL & CSA Listings.

**THREE PHASE AUTOMATIC UNITS AVAILABLE IN 230V SINGLE SEAL ONLY.

© Copyright 2006 Zoeller Co. All rights reserved.

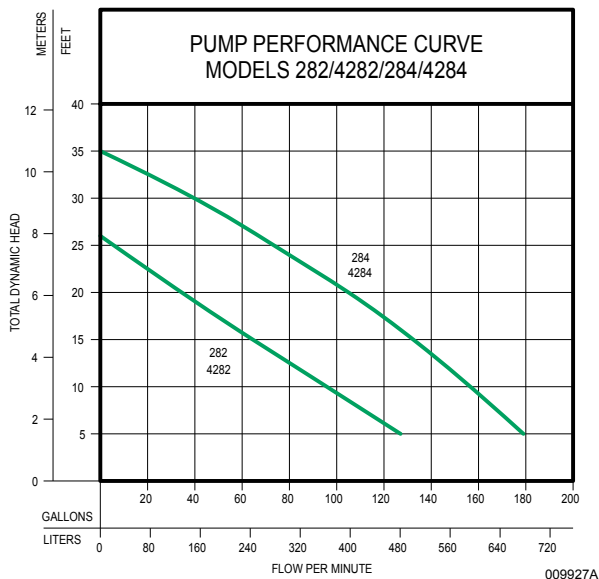

MODELS		282/4282		284/4284	
Feet	Meters	Gal.	Liters	Gal.	Liters
5	1.5	127	481	179	678
10	3.0	96	363	157	594
15	4.6	64	242	133	503
20	6.1	34	129	106	401
25	7.6	6	23	73	276
30	9.1	--	--	42	159
Shut-off Head		26 ft. (7.9m)		35 ft. (10.7m)	

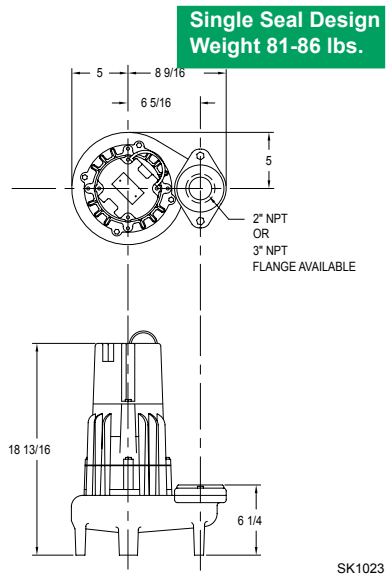

CONSULT FACTORY FOR SPECIAL APPLICATIONS

- Three phase pumps are available in 200V, 230V, or 460V. 230V three phase is available in automatic and nonautomatic models.
- Electrical alternators, for duplex systems, are available and supplied with an alarm.
- Mechanical alternators, for duplex systems, are available with or without alarm switches.
- Combination starters are available.
- Variable level control switches are available for controlling single and three phase systems.
- Double piggyback variable level float switches are available for variable level long cycle controls.
- Long cords are available in lengths of 25 - 35 - 50 feet.
- Simplex and duplex basins are available.
- Refer to FM1922 and FM0806 for temperatures over 130°F.

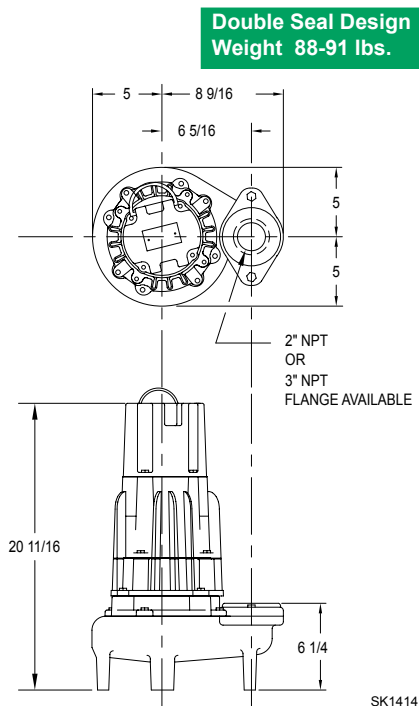

SPECIFICATIONS								CONTROL SELECTION		Listings	
Single Seal Model	Double Seal Model	Volt-Phase	Mode	Amps	HP	Cord Lgth.	Simplex	Duplex	CSA	UL	
M282	-----	115	1Ph	Automatic	10.3	1/2	10	1	-----	Y	Y
N282	N4282	115	1Ph	Nonauto	10.3	1/2	15	2 or 3	4	Y	Y
D282	-----	230	1Ph	Automatic	5.0	1/2	10	1	-----	Y	Y
E282	E4282	230	1Ph	Nonauto	5.0	1/2	15	2 or 3	4	Y ⁽¹⁾	Y
* H282	-----	200	1Ph	Automatic	6.1	1/2	10	1	-----	N	N
* I282	*I4282	200	1Ph	Nonauto	6.1	1/2	15	3	4	N	N
* J282	*J4282	200	3Ph	Nonauto	3.6	1/2	15	3	4	Y	Y
* F282	*F4282	230	3Ph	Nonauto	3.0	1/2	15	3	4	Y	Y
* CF282	-----	230	3Ph	Automatic	3.0	1/2	15	1	-----	N	Y
* G282	*G4282	460	3Ph	Nonauto	1.7	1/2	15	3	4	Y	Y
D284	-----	230	1Ph	Automatic	8.9	1	10	1	-----	Y	Y
E284	E4284	230	1Ph	Nonauto	8.9	1	15	2 or 3	4	Y ⁽¹⁾	Y
* H284	-----	200	1Ph	Automatic	9.3	1	10	1	-----	N	N
* I284	*I4284	200	1Ph	Nonauto	9.3	1	15	3	4	N	N
* J284	*J4284	200	3Ph	Nonauto	5.5	1	15	3	4	N	Y
* F284	*F4284	230	3Ph	Nonauto	5.0	1	15	3	4	Y	Y
* CF284	-----	230	3Ph	Automatic	5.0	1	15	1	-----	N	Y
* G284	*G4284	460	3Ph	Nonauto	2.6	1	15	3	4	Y	Y

* No Molded Plug
(1) CSA Approval without plug.

SELECTION GUIDE

1. Integral float operated mechanical switch, no external control required.
2. For automatic use single piggyback variable level float switch or double piggyback variable level float switch. Refer to FM0477.
3. See FM1228 for correct model of simplex control panel.
4. See FM0712 for correct model of duplex control panel.

CAUTION

For information on additional Zoeller products refer to catalog on Piggyback Variable Level Float Switches, FM0477; Electrical Alternator, FM0486; Mechanical Alternator, FM0495; Sump/Sewage Basins, FM0487; Simplex Pump Control, FM1596; Alarm Systems, FM0732; and Disconnect/Rail Systems, FM0787.

All installation of controls, protection devices and wiring should be done by a qualified licensed electrician. All electrical and safety codes should be followed including the most recent National Electric Code (NEC) and the Occupational Safety and Health Act (OSHA).

RESERVE POWERED DESIGN

For unusual conditions a reserve safety factor is engineered into the design of every Zoeller pump.

© Copyright 2006 Zoeller Co. All rights reserved.